

ストレートワルツ

竹内啓

6枚用意する

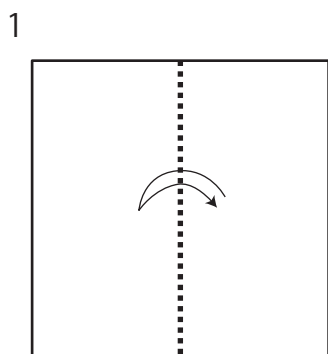

折り筋を付ける

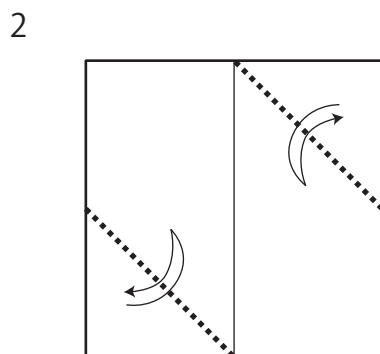

折り筋を付ける

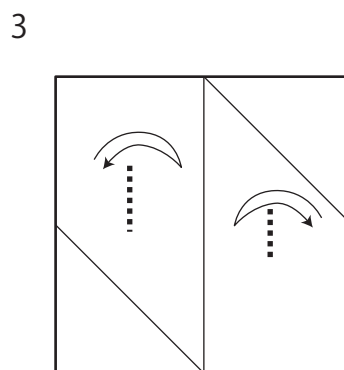

印を付ける

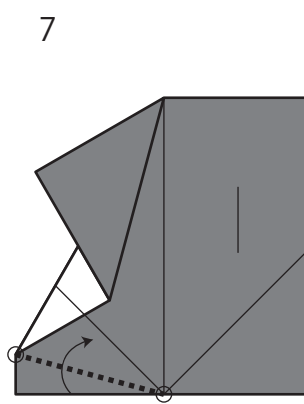
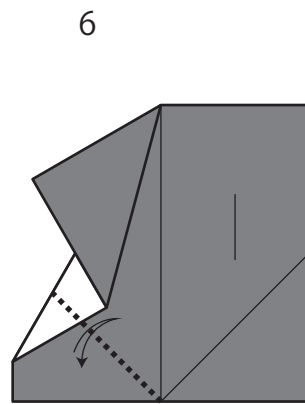
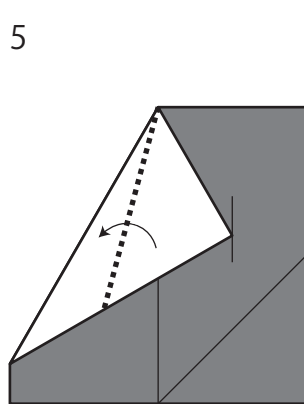
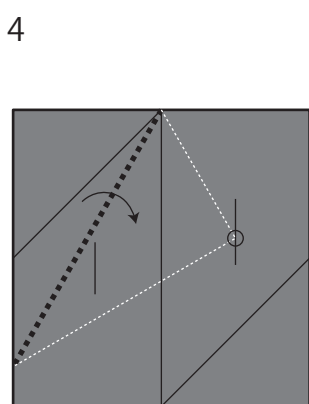

折り筋を付ける

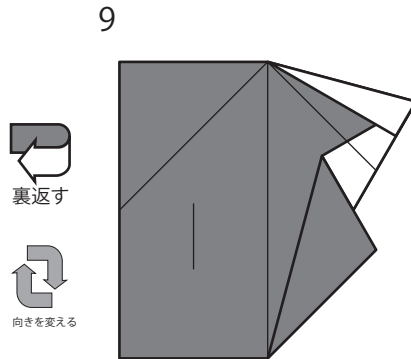
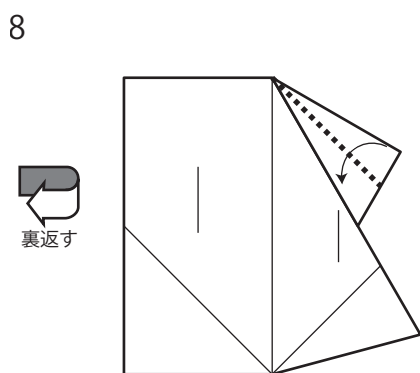

5~8を繰り返す

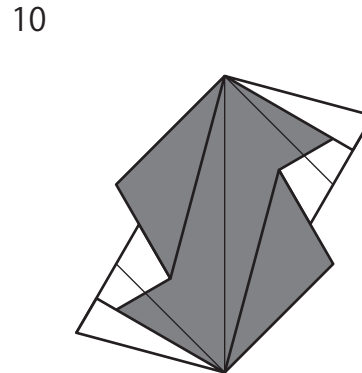

完成

組み立て

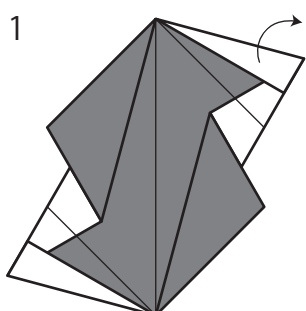

戻す

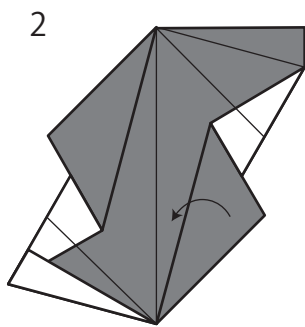

戻す

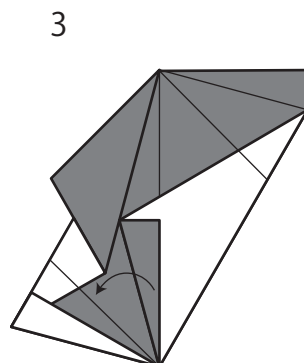

戻す

4

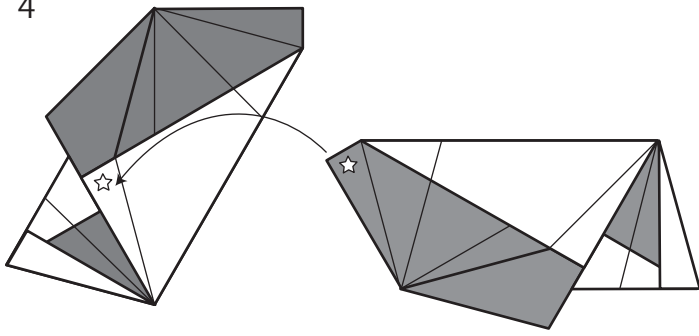

重ねる

5

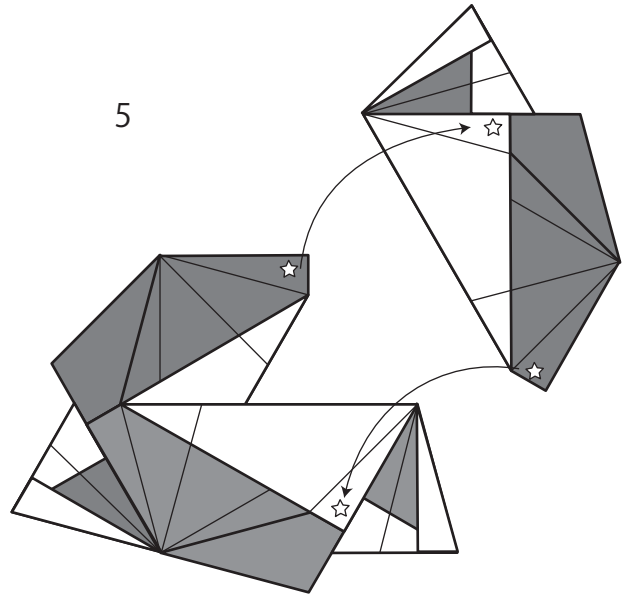

重ねる

6

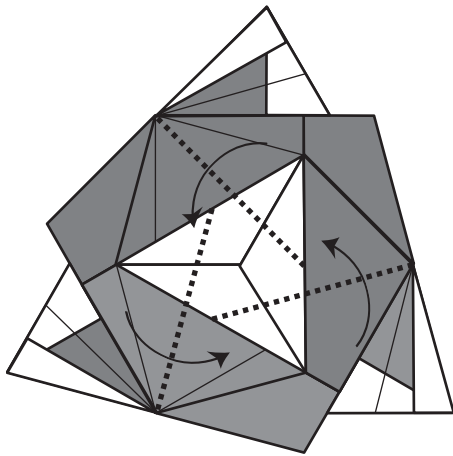

7

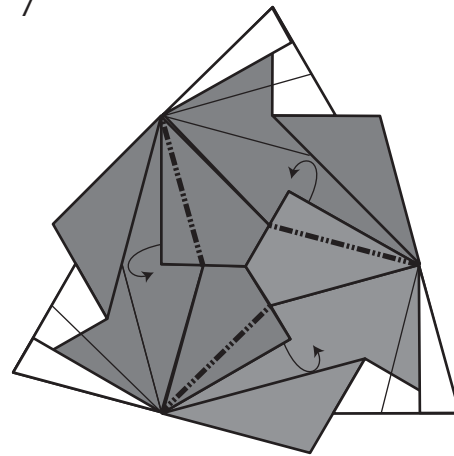

紙を隙間に入れて
引っ掛ける

8

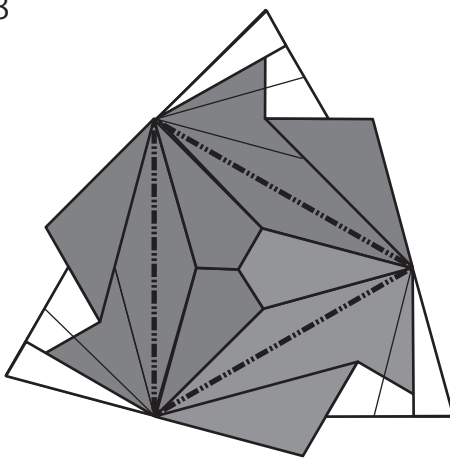

他の面も同じように

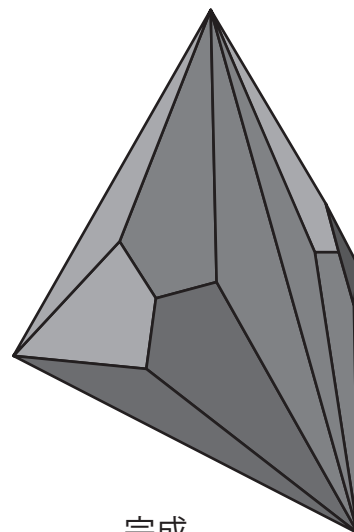

完成